

# XU Series

## Continuous Gravimetric Powder Blender



### ***The XU Series: designed to produce precise, homogeneous powder blends by weight (pictured is an XUC4)***

The XU Series Continuous Gravimetric Powder Blender offers unsurpassed blend accuracy and blend homogeneity in a wide range of configurations to meet the needs of any application by incorporating the PF Series powder feeders. It allows gravimetric blending of non-free-flowing powder materials with free-flowing powder and pellet materials at unprecedented metering and mixing accuracy.

The powder feeders allow rates as low as 0.2 PPH and as high as 3,000 PPH. Metering augers are available in full pitch or 1/2 pitch configurations with helix diameters from 1/4 inch to 2-1/4 inches.

The drive system of all blender components utilizes a PWM drive with a

DC gearmotor and encoder for accurate motor speed feedback. This allows each of the individual feeders to maintain a constant RPM and weight throughput.

The weighing system is designed with DSP (digital signal processing) technology (patent pending) to filter out unwanted noise and vibration which can wreak havoc with any feeding system, especially at very low feed rates.

Incorporated into the electro-polished stainless steel design is a patented round-to-trough feeding area which provides more consistent mass flow for better metering accuracy. The feeder is designed with a steep wall, removable hopper which features a dust-tight band clamp for

easy mounting of hopper extensions and quick disassembly for clean out. The bottom trough design is optimized to provide maximum material exposure to the auger.

The XU Series Continuous Powder Blender is also available in food grade stainless steel.

The operator enters the desired blend recipe at the operator station. All ingredients are simultaneously metered in the correct blend ratios by augers from individual weighed PF Series powder feeders. The ingredients then flow through a cascade chamber which produces the best blend homogeneity.

### **Standard Features**

- All mechanical components are disassembled from the drive end, without the uses of tools
- Communication protocols supported include: EtherNet/IP, Allen Bradley [dh+], CCM, Siemens 3694, Profibus, DeviceNet, ControlNet, SPI, Modbus TCP and Modbus/Extended, as well as proprietary EPCC and ASCII
- 4 or 6 element frames for mounting a variety of feeder options

### **Options**

- Pellet/Regrind element
- Gravimetric Extrusion Control
- Steep-wall surge bins with knife gates
- High temperature design
- FDA stainless steel

### **Power**

- 115 V/ 1 Ph/ 60 Hz

# Features of XU Series Continuous Powder Blender

## 1 Universal Frame

The universal frame is available in 4 and 6 element configurations.

## 7 Cascade Chamber

The cascade chamber is for mixing all of the ingredients.

## 2 Stainless Steel Weigh Hopper

The stainless steel weigh hoppers are electro-polished and available in food grade.

## 6 Auger

The auger has a 1/2 - 1" pitch and up to 2 1/4" diameter.

## 3 Gear Motor

The gear motor is a PWM drive and encoder with high accuracy.

## 4 Feeding Area

The feeding area is round-to-trough and agitated.

## 5 Dual Load Cell

The dual load cells are weighing platforms with quick clamps.

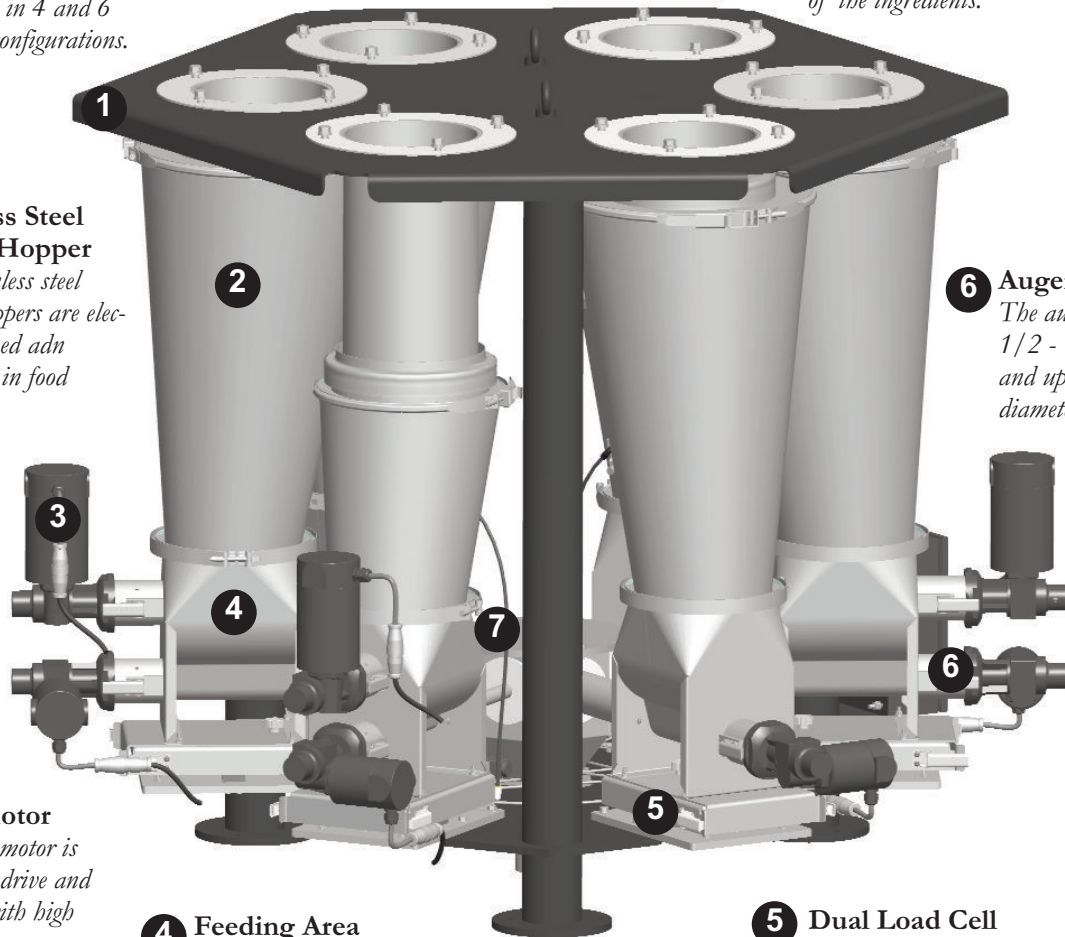

### Mechanical Features

- Individual weighed ingredient hoppers with easy-to-use drains
- Interchangeable metering units with quick disconnect
- DC gearmotors with PWM drive control and closed-loop speed regulation
- Integral loading platform for mounting surge bins/vacuum receivers
- Designed for easy cleanout and quick changeover, no tools required
- Stainless steel construction, food grade optional
- Standard 4 and 6 element universal frames

### Control Features

- Powerful microprocessor control system with user friendly operating software
- Blender monitors weight loss of each ingredient hopper for precise control of blend ratios
- Weighing system resolution is 1:1,000,000 for maximum accuracy
- Vacuum fluorescent display for easy viewing of inventory and performance data
- Storage for 400 blend recipes in battery-backed memory
- Multiple alarm levels with visual display and contact closures



**PROCESS CONTROL Corporation**  
**World Headquarters**  
 6875 Mimms Drive, Atlanta, GA 30340 USA  
 Tel: (770) 449-8810 Fax: (770) 449-5445  
[www.process-control.com](http://www.process-control.com)

**Process Control China Limited**  
 Guangzhou, GuangDong Province, China  
 TEL: +8620 28395688 FAX: +8620 28395773  
**Process Control GmbH**  
 Birstein, Germany  
 TEL: +49-6054-91 29-0 FAX: +49-6054-91 29-95