

HGB Series

GRAVITROL® Weigh Hopper



The HGB Series: the precise weigh hopper component of an integrated Gravitrol® system (picture above is an HGB023)

Designed for use as part of the Gravitrol® system, the HGB Series Weigh Hopper incorporates engineering and design breakthroughs to help achieve the optimal result in extrusion: a uniform product within tolerance at the lowest possible manufacturing cost.

The Gravitrol® system gives you total control over your mono-extrusion or coextrusion processes. The system can be configured to control extruder rate by weight; layer percentages by weight; weight of extrudate by length; average

thickness; and pipe or tube diameter.

The HGB Series Weigh Hopper is a central part of this system because it precisely monitors the amount of material consumed by the extruder. In effect, the extruder becomes a gravimetric metering device.

PCC's HGB mounts directly on the throat of your extruder, requiring no additional support. Standard hopper sizes control an extruder throughput at rates from 10 to 10,000 PPH. Higher-rate hoppers are

available on special order.

The HGB Series' clear polycarbonate inspection/clean out door or sight glass allows visual inspection of hopper contents.

Each hopper has a PCC-designed and built Weigh Module which connects to the load cell and precisely measures the extruder's material consumption. This information is digitized on the hopper for fast, error-free and noise-immune communications with the central Gravitrol® computer. Four-point overload protection on the hopper protects the weighing system from damage due to accidental contact. ■

Standard Features

- Integral loader support platform
- Clear polycarbonate inspection/cleanout door (on 2.3 cu. ft. models and larger)
- Inspection sightglass on 0.3 cu. ft. and 0.6 cu. ft. models
- Butterfly drain valve (on 2.3 cu. ft. models and larger)
- High-resolution DSP weighing system
- Integrates with a complete Gravitrol® extrusion control system for precise, consistent throughput control
- Mild steel construction

Options

- High temperature design
- Stainless steel construction
- Special electricals
- Positive shut-off knife-gate or swing-gate valve for gravity loading material from above

HGB Series Gravitrol® Weigh Hopper

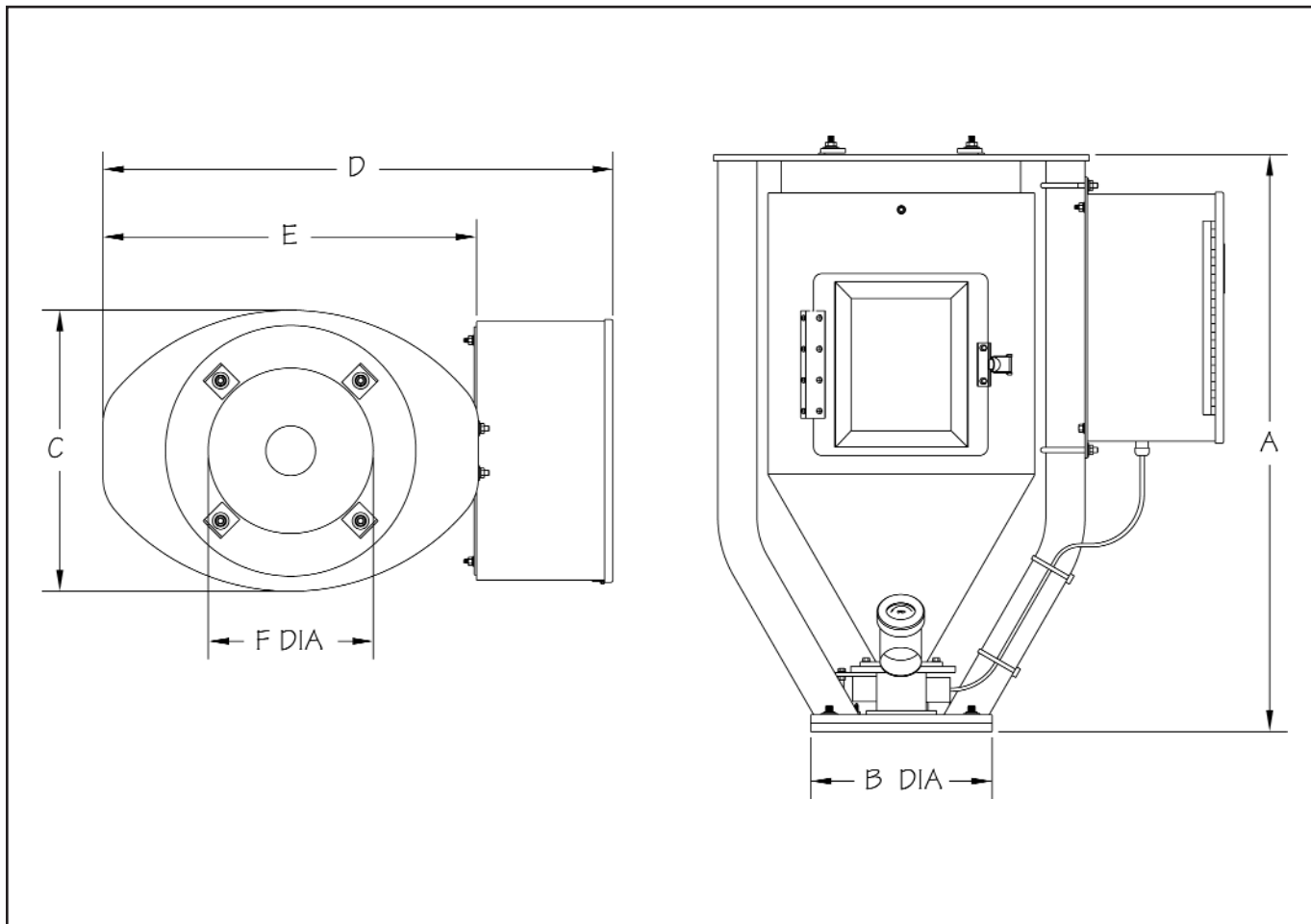

SPECIFICATIONS for HGB SERIES WEIGH HOPPER

Model Number	Working Capacity cu.ft. (dm ³)	Dimensions - Inches (mm)						EXTRUDER SIZE		Shipping Weight Lbs (kg)
		A	B	C	D	E	F	MIN	MAX	
HGB003	0.3 (8.5)	28.3 (719)	10.0 (254)	11.0 (279)	24.1 (613)	15.7 (400)	7.8 (197)	1.0 (25)	2.0 (51)	60 (27)
HGB006	0.6 (17.0)							1.5 (38)	2.5 (64)	
HGB019 *	1.9 (53.8)	37.3 (946)	11.0 (279)	17.0 (432)	30.9 (784)	22.6 (575)	10.0 (254)	2.0 (51)	4.5 (114)	115 (70)
HGB023	2.3 (65.1)	34.8 (883)						2.5 (64)	6.0 (152)	
HGB045	4.5 (127.4)	53.5 (1359)						3.5 (89)	8.0 (203)	

* Hopper is steep wall configuration for flowable powder



PROCESS CONTROL Corporation

World Headquarters

6875 Mimms Drive, Atlanta, GA 30340 USA

Tel: (770) 449-8810 Fax: (770) 449-5445

www.process-control.com

PROCESS CONTROL GmbH

Industriestrasse 15, 63633 Birstein, Deutschland

Tel: (+49) 0 60 54-91 29 0 Fax: (+49) 0 60 54-91 29 99

E-Mail: ProcessControl@t-online.de