

PT Series

Pneumatic Box Tilter



The PT Series: smooth tilt action with easy on & off placement

Process Control's PT Series Floor Level Box Tilter is an easy-to-use gaylord container tilter which offers fork truck, pallet jack, or hand truck loading of bulk containers. Its rugged construction and reliable operating assemblies assure long lasting, dependable operation. By adjusting the PSIG on the air bag to a prescribed setting, a constant pressure slowly lifts the Gaylord automatically as it empties and becomes lighter. This action moves the material to the corner and allows the pick-up lance to completely empty the container. Most loose materials will empty completely. However, for dif-

ficult flowing materials, an optional vibration package is available. An adjustable wand holder is provided to facilitate easy attachment of a standard vacuum pick-up lance. ■

Standard Features

- Capacity: 2,000 lbs maximum
- Base Dimensions: 71" x 52"
- Floor space requirement: 71" x 80"
- Floor level entry provides easy loading and unloading of containers
- Adjustable pick-up lance holder
- Tilts container to 45 degrees
- Tilt bucket drops flat on the floor
- Easy loading and unloading of containers
- Flexibility with entry from two different angles
- Smooth lifting with air bag device which is coupled with a pressure regulator and gauge
- Setting the PSIG allows tilter to lift with a constant pressure so material moves toward wand for complete cleanout
- Hand control
- Power system: air (40-100 psi required)
- Heavy-duty mild steel construction

Options

- Vibrator for difficult flowing materials
- Casters
- Special Paint

PT Series Pneumatic Box Tipper

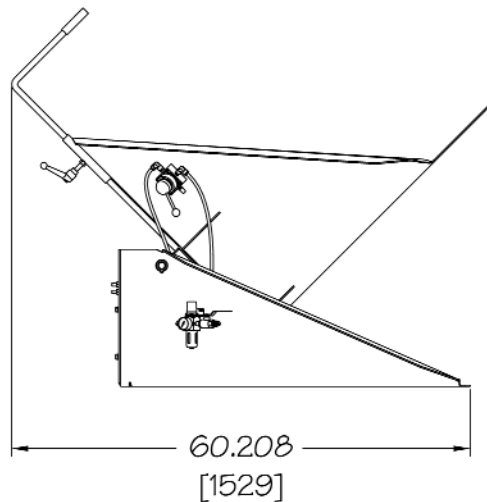
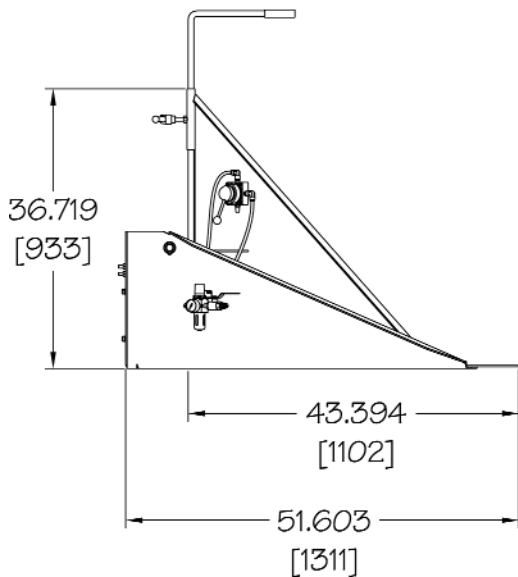
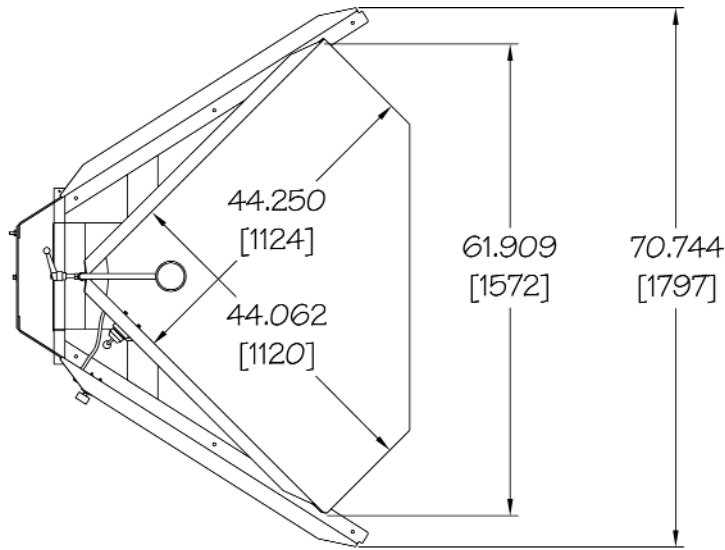

Capacity: 1500 lbs [682 kg]

Shipping weight: 510 lbs [232 kg]

[] dimensions are metric



PROCESS CONTROL Corporation
World Headquarters
6875 Mimms Drive, Atlanta, GA 30340 USA
Tel: (770) 449-8810 Fax: (770) 449-5445
www.process-control.com

PROCESS CONTROL GmbH
Industriestrasse 15, 63633 Birstein, Deutschland
Tel: (+49) 0 60 54-91 29 0 Fax: (+49) 0 60 54-91 29 99
E-Mail: ProcessControl@t-online.de