

# VL Series

## Vacuum Power Unit



*The VL Series: designed for use in a dual-blower system for conveying of plastic materials; part of a complete materials handling system (pictured above if a VL5055).*

Process Control Corporation specializes in equipment for bulk conveying of plastic materials. Our conveying equipment is designed to stand up to the toughest demands of your application, including high material flow rates, multiple distribution points and long conveying distances.

To prevent bottle necking and ensure a continuous supply of material to any number of plant sites (silos, surge buns, processing machines, blenders, etc.), Process Control engineers work with you to select the best equipment and integrate it into a reliable system capable of continuous operation and guaran-

teed performance.

The VL Series Vacuum Power Unit is designed for use as part of a complete dual-blower railcar or truck unloading system.

The VL Series Vacuum Power Unit pulls material (using vacuum) from a source to a T Series Transfer Station (available separately). Then, the material drops through a rotary feeder to a blowthrough powered by a P Series Pressure Power Unit (available separately). The material is then conveyed using pressure to one or many selected distribution points. The VL Series can be part of integrat-

ed materials handling system designed to meet your specific needs.

Process Control supplies a complete line of material handling equipment including tubing and hardware, vacuum pumps, controllers, bolted & welded storage silos and daybins. ■

### Standard Features

- 10 to 50 horsepower available
- Positive displacement blower
- T-frame TEFC motor
- Dual-stage intake filter
- Discharge silencer designed for effective sound reduction
- Vacuum relief valve and gauge
- Reinforced, heavy steel base plate
- Four-sided belt guard with removable access cover
- Electricals and controls in a NEMA-12 enclosure
- Power: 460V/3PH/60Hz

### Options

- Special motors
- Special electricals
- Fused disconnect panel
- Proofing interlocks
- Level controls at storage/ use points
- Special paint

# VL Series Vacuum Power Unit

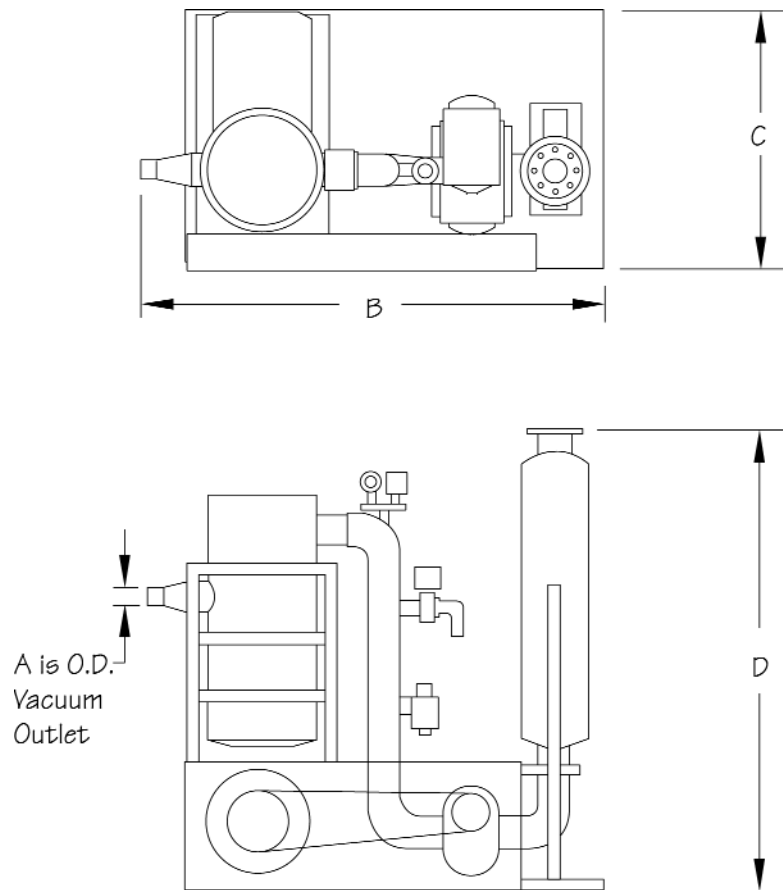

Every unit is factory tested before shipment. Information is subject to change without notice.

## Specifications for VL Series Vacuum Power Unit

Model Number	HP (KW)	Dimensions - Inch (mm)				Shipping Weight lbs. (kg)
		A	B	C	D	
VL1025	10 (7.5)	2.5 (64)	55.0 (1397)	29.0 (732)	60.0 (1524)	725 (1595)
VL1530	15 (11.3)	3.0 (76)	78.0 (1981)	36.0 (914)	78.0 (1981)	1,055 (2321)
VL2035	20 (15.0)	3.5 (89)				1,220 (2684)
VL2540	25 (18.8)	4.0 (102)				1,275 (2805)
VL3045	30 (22.5)	4.5 (114)			93.0 (2362)	1,410 (3102)
VL4050	35 (26.3)	5.0 (127)				1,450 (3190)
VL5055	40 (30.0)	5.5 (140)	84.0 (2134)	42.0 (1067)	106.4 (2692)	1,725 (3795)



**PROCESS CONTROL Corporation**  
**World Headquarters**  
 6875 Mimms Drive, Atlanta, GA 30340 USA  
 Tel: (770) 449-8810 Fax: (770) 449-5445  
 www.process-control.com

**PROCESS CONTROL GmbH**  
 Industriestrasse 15, 63633 Birstein, Deutschland  
 Tel: (+49) 0 60 54-91 29 0 Fax: (+49) 0 60 54-91 29 99  
 E-Mail: ProcessControl@t-online.de