

VP Series

Vacuum/Pressure Power Unit



The VP Series: designed for bulk unloading plastics from trucks or railcars

Process Control's material handling equipment is specially designed for bulk conveying of plastic materials. Years of experience with plastics processors enables Process Control engineers to size conveying equipment for reliable, cost-effective loading of gravimetric and bulk systems.

The VP Series Vacuum/Pressure Power Unit is typically used as part of a truck or railcar unloading system. It is designed to pull material to its transfer station, where it passes through a rotary feeder to the pressure side of the system. The material is then blown to storage container such as a silo or daybin. The VP Series can be part of an integrated plant distribution system designed by Process Control to meet your spe-

cific needs. Process Control supplies a complete line of material handling equipment including hardware, pumps, receivers, controllers, silos and daybins.

For higher rate requirements, separate vacuum and pressure power units are teamed with a CH Series transfer station to achieve the same function as the integrated VP Series power unit.

To ensure a continuous supply of material to any number of plant sites, Process Control Engineers work with you to select the best equipment and integrate it into a system capable of continuous operation and guaranteed performance.

Standard Features

- 20 to 50 horsepower available
- Positive displacement blower
- T-frame TEFC motor
- Enclosed V-belt drive
- Dual-stage intake filter
- Discharge silencer
- Vacuum relief valve and gauge
- Level control

Options

- Special Paint
- Special electricals
- Fused panel disconnect
- Level controls at storage or use points
- Proofing interlocks

Vacuum/Pressure Power Unit

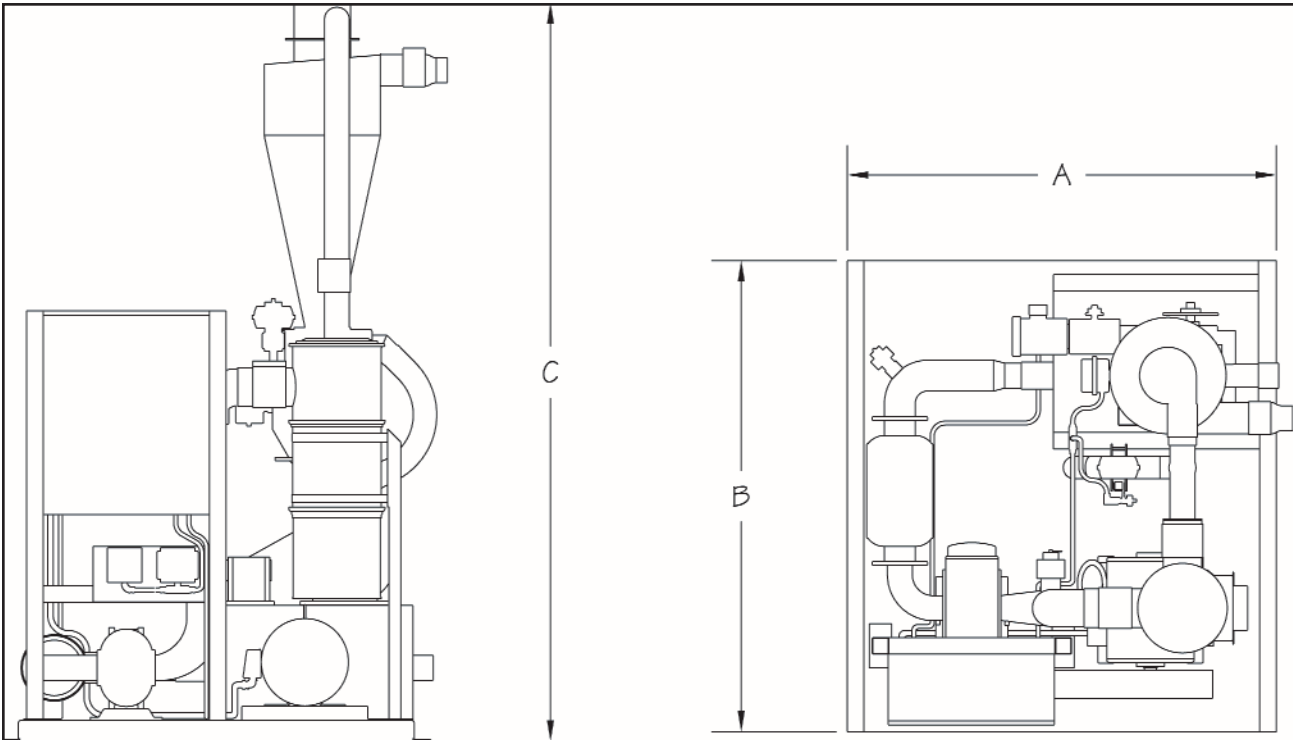

Information is subject to change without notice.
Use only certified drawings for construction purposes

SPECIFICATIONS FOR VP SERIES VACUUM/PRESSURE POWER UNIT

Model Number	HP (kW)	Rotary Feeder HP (kW)	Dimensions in (mm)			Shipping Weight lbs (kg)
			A	B	C	
VP10D	10 (7.5)	0.75 (0.5)	59 (1500)	71 (1820)	121 (3080)	2440 (1110)
VP15E	15 (11)		73 (1854)	64 (1630)	132 (3360)	2665 (1210)
VP25G	25 (19)	1.0 (0.75)	77 (1970)	85 (2160)	127 (3230)	2795 (1270)
VP30H	30 (22)					3390 (1540)
VP40H	40 (30)	1.5 (1.1)	142(3600)*	89 (2260)*	112 (2850)	3580 (1630)
VP50K	50 (37)					3620 (1645)

*VP50 is modular design



PROCESS CONTROL Corporation

World Headquarters

6875 Mimms Drive, Atlanta, GA 30340 USA

Tel: (770) 449-8810 Fax: (770) 449-5445

www.process-control.com

PROCESS CONTROL GmbH

Industriestrasse 15, 63633 Birstein, Deutschland

Tel: (+49) 0 60 54-91 29 0 Fax: (+49) 0 60 54-91 29 99

E-Mail: ProcessControl@t-online.de