

# USED EQUIPMENT

## For Sale

Guardian® 5kg, 6 element  
Batch Blender with Color  
Touch Screen Controls

## Features

- Integral loading platform for mounting vacuum receivers
- Attached air hose and nozzle for cleaning
- Support for a wide variety of communications protocols
- Pulsing V-gate metering designed to accurately meter each ingredient in every batch
- Advanced mechanical agitator in a “No Dead Zone” mixing chamber for precise blend homogeneity.
- Integral drain chute provides for fast and thorough cleanout.
- Color touch screen operator interface with new “off-the-shelf” control



## Accuracy Statement

Process Control engineers have produced a highly advanced dispensing and weighing system that accurately controls each ingredient of every batch to the desired amounts and is not averaged over multiple batches as is common in other batch blenders in the industry. At the blender's highest setting, each ingredient can be dispensed to an accuracy of  $\pm 0.02\%$ .

In addition to precise batch-to-batch dispensing, the performance of the mixer is just as critical to the end product. The mixer actually determines how uniform the blend will be. Inadequate mixing can lead to inconsistent product characteristics such as color variations or other imperfections.

The Guardian® Series blenders have incorporated a built in clean-out system in the design. With a pull-out drain chute and separate manual slide-gate controls, the blender can be cleaned out quickly and easily during product changeovers.

## Price

\$13,570.00

## Contact

[sales@process-control.com](mailto:sales@process-control.com)



## PROCESS CONTROL CORPORATION

### World Headquarters

6875 Mimms Drive, Atlanta, GA 30340 USA  
Ph 770.449.8810 Fax 770.449.5445

### Process Control GmbH

Birstein, Germany  
Ph +19-6051-91 29-0 Fax +19-6051-91 29-99

# 6 Element, 5 KG Guardian Blender

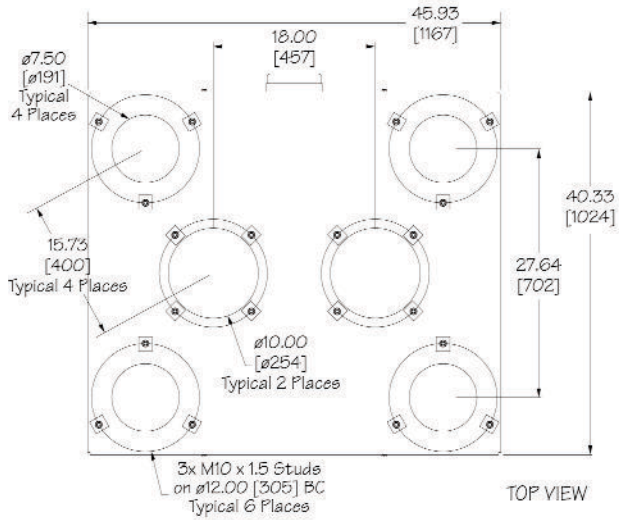

TOP VIEW

**Maximum Throughput Rates:**  
**5-Element: 1600 PPH\***  
**6-Element: 1350 PPH\***  
**\*Depending on Materials & Accuracy Setting**

Power: 115V/1PH/60Hz or  
 230V/1PH/50Hz

[ ] Dimensions are in mm

Approximate shipping weight: 650 lbs.

VIEW OF MOUNTING PLATE

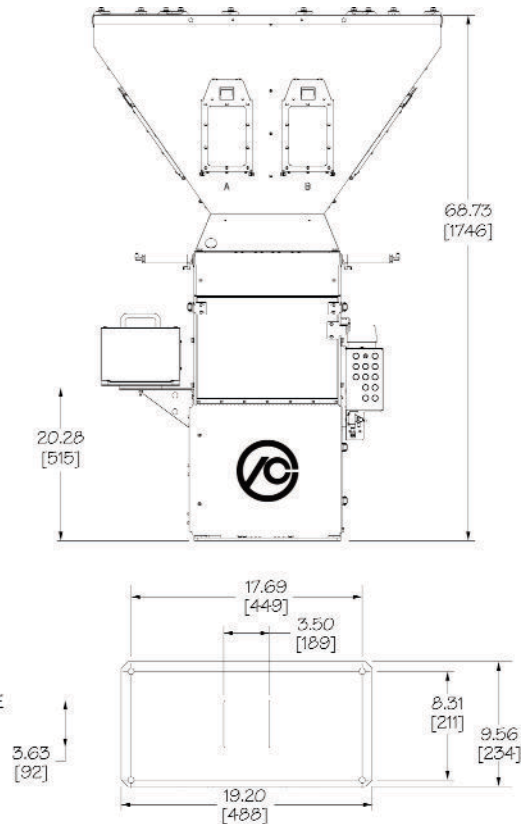

# 6 Element, 12 KG Guardian Blender

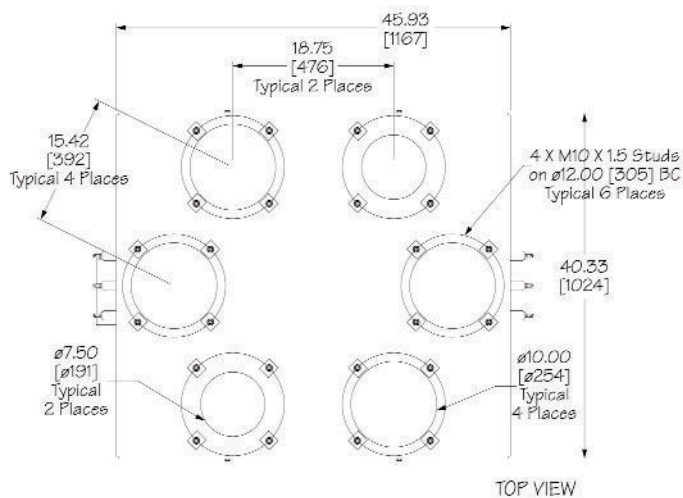

TOP VIEW

**Maximum Throughput Rates:**  
**5-Element: 2900 PPH\***  
**6-Element: 2800 PPH\***  
**\*Depending on Materials & Accuracy Setting**

Power: 460V/3PH/60Hz or  
 380V/3PH/50Hz

[ ] Dimensions are in mm

Approximate shipping weight: 700 lbs.

VIEW OF MOUNTING PLATE

