

CH Series

Transfer Station



The CH Series: designed for use with a dual blower conveying system

Process Control Corporation specializes in equipment for bulk conveying of plastic materials. The equipment is designed to stand up to the toughest demands of your application, including high material flow rates, multiple distribution points and long conveying distances.

The CH Series transfer station, with cyclone, is designed for use in dual blower conveying systems. Used in conjunction with the VL Series vacu-

um pump and P series pressure pump (both available separately), the CH Series is used to transfer the material from the vacuum part of the system to the pressure part of the system. The VL pump creates the vacuum which pulls the material from a railcar or truck into the cyclone mounted on top of the transfer station. The material then drops down, through a rotary airlock feeder, into a blow through assembly. The P series then applies the pres-

sure to convey the material to its storage point, silo or daybin. Process Control engineers are always available to assist you in designing the best system to meet your application. Process Control supplies a complete line of material handling equipment including tubing and hardware, vacuum and pressure pumps, controllers, silos and daybins. ■

Standard Features

- Rotary feeder with shear eliminator and vent
- Polyphase gearmotor
Power: 460V/3Ph/60Hz
- High efficiency cyclone designed for air flow as required
- Level control rotary vane, electro-mechanical type
- Four-sided chain guard w/removable access cover
- Reinforced heavy steel base plate
- Mild steel construction

Options

- Special motor
- Special electricals
- Epoxy coating
- Stainless steel construction
- Special paint
- Baghouse type filter

T Series Transfer Station

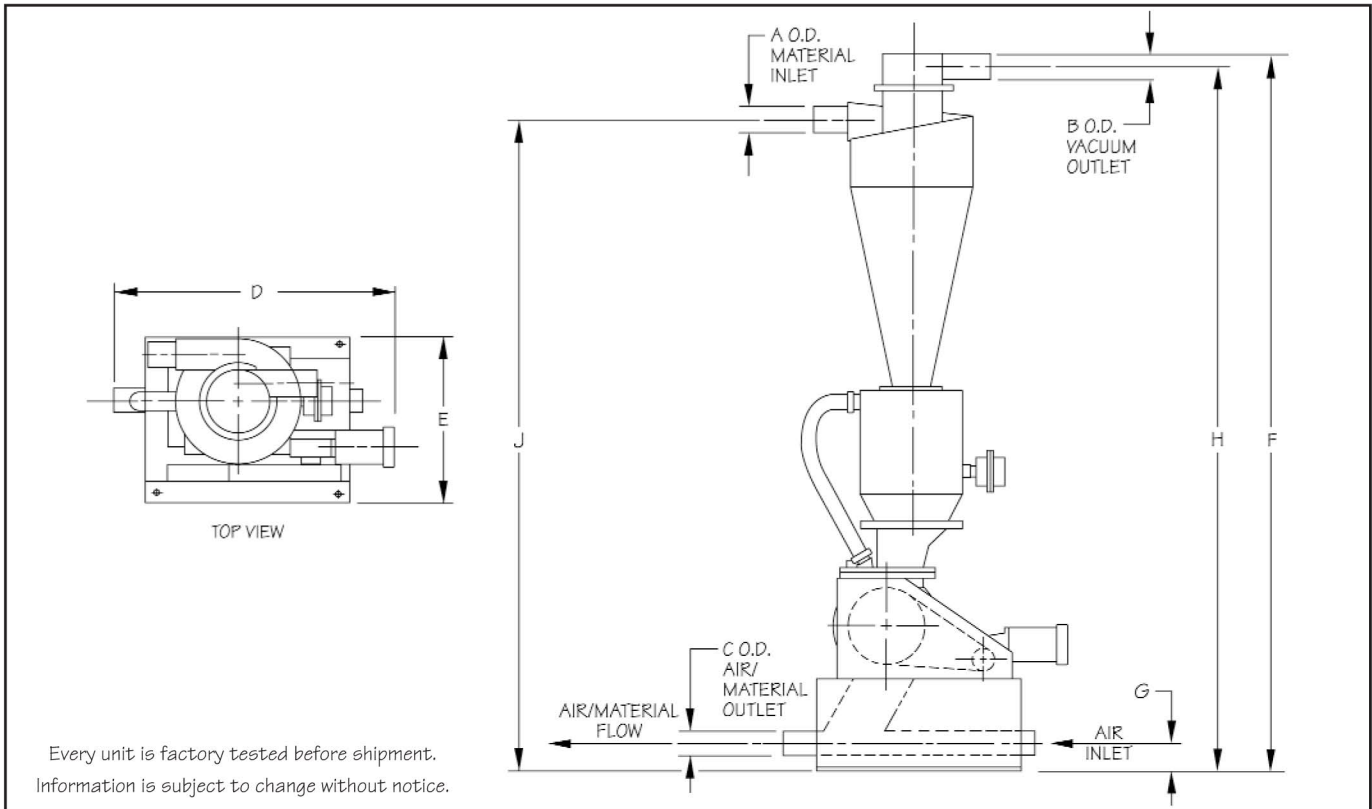

Specifications for T Series Transfer Station

Model	Rotary Feeder HP	Dimensions - Inch (mm)								Shipping Weight lbs. (kg)
		A & B	C	D	E	F	G	H	J	
CH25_825_	.75 (kw)	2.50 (64)	2.50 (64)	45.50 (1149)	23.00 (584)	115.00 (2921)	9.41 (239)	113.75 (2889)	103.50 (2629)	1217 (553)
CH30_1025_	1.0 (kw)	3.00 (76)		48.25 (1226)	26.50 (673)	123.00 (3124)		119.97 (3047)	111.30 (2827)	1626 (739)
CH35_1030_		3.50 (89)	3.00 (76)	123.25 (3131)	121.74 (3092)	112.72 (2863)		1639 (745)		
CH40_1235_	1.5 (kw)	4.00 (102)	3.50 (89)	49.75 (1264)	30.50 (774)	131.00 (3327)		112.36 (2854)	126.65 (3217)	1826 (830)
CH45_1240_		4.50 (114)			4.00 (102)	132.25 (3359)		103.34 (2625)	112.60 (2860)	1837 (835)
CH50_1440_	2.0 (kw)	5.00 (127)	5.00 (127)	51.50 (1308)		36.50 (927)		147.50 (3747)	119.72 (3041)	130.72 (3320)
CH55_1445_		5.50 (140)			4.50 (114)	148.25 (3766)		2174 (988)		



PROCESS CONTROL Corporation
World Headquarters
 6875 Mimms Drive, Atlanta, GA 30340 USA
 Tel: (770) 449-8810 Fax: (770) 449-5445
 www.process-control.com

PROCESS CONTROL GmbH
 Industriestrasse 15, 63633 Birstein, Deutschland
 Tel: (+49) 0 60 54-91 29 0 Fax: (+49) 0 60 54-91 29 99
 E-Mail: ProcessControl@t-online.de