



**PROCESS CONTROL CORPORATION**  
Quality Auxiliary Equipment for the Plastics Processing Industry



**GRAVIMETRIC  
BLENDING  
SINCE 1967**



## WHO WE ARE

Established in 1967, Process Control Corporation has supplied plastics processors with world class auxiliary equipment for almost half a century.

From our world headquarters in Atlanta Georgia, Process Control provides manufacturing, marketing project engineering, sales, and customer support for the US, Canada, Mexico, and both Central and South America

## WHAT WE DO

**QUALITY EQUIPMENT** featuring Gravimetric Continuous and Gravimetric Batch Blenders and Material Handling Systems

**ACCURATE EQUIPMENT** with a tested and proven blending accuracy of 0.02% for the Guardian® Series Blender.

**CUSTOMER SERVICE** technicians supporting you anywhere in the world and in house experts to assist over the phone.

**INNOVATIVE DESIGN** starting with your companies' needs and after the design is completed by our expert Engineers the equipment will be fabricated 100% in house by our Production and Manufacturing team members.

**UNENDING COMMITMENT** to excellence is what keeps our customers coming back; it's who we are, it's what we do.



## PCC GmbH

Our Subsidiary, Process Control GmbH, continues the PCC legacy by achieving enormous success in one of the most competitive European markets.

PCC GmbH was established in 1994 and handles project engineering, manufacturing, sales, marketing and customer service support for continental Europe, India, Africa Asia, the Middle East and Australia.



## ASR<sup>®</sup> Automatic Scrap Recycling Systems

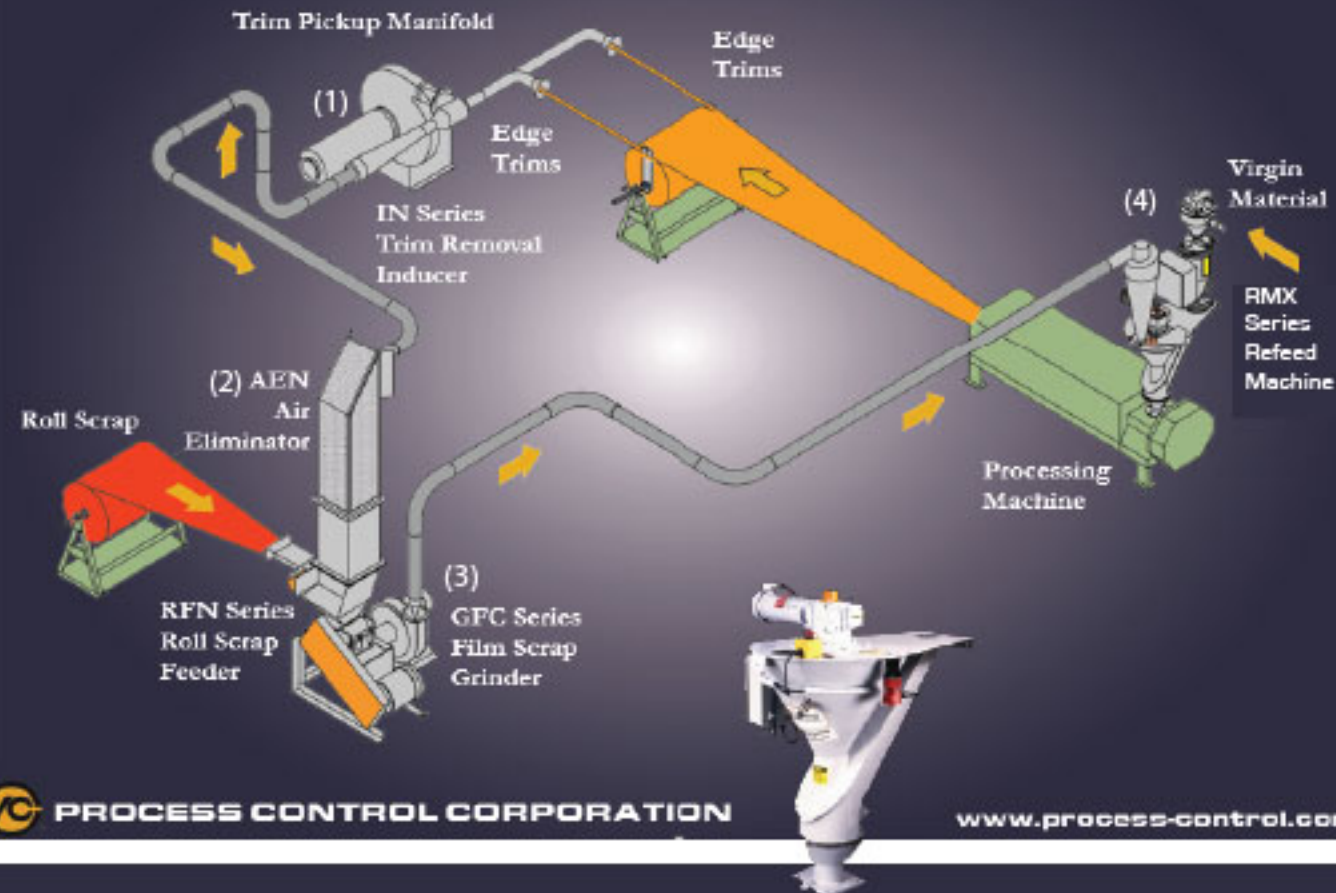

**PROCESS CONTROL CORPORATION**

[www.process-control.com](http://www.process-control.com)

### Complete ASR<sup>®</sup> System

(1) Inducer: takes edge and bleed trims or tapes from the extrusion line conveying it to the (2) Air Eliminator: mounted on the film scrap (3) Grinder. Roll scrap and/or loose scrap can be introduced into the Grinder which sends ground scrap to the (4) RMX refeed machine where it is metered with virgin pellet material into the production extruder at a constant virgin-to-scrap ratio.

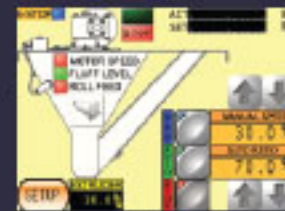

The RMX Refeed Machine's HMI-Touchscreen Operator Panel

### Features

Restores scrap to full base material value.

No inventory of lower value repelletized material.

Avoids additional heat and energy costs associated with repelletizing.

Avoids potential contamination of scrap materials.

Maintains a high product quality.

System follows the extruder rate.

No extruder surge or starvation.

Simple line start-up.

Low operating cost and High ROI.



## IN SERIES Trim Removal Inducer



IN Series Inducers are designed to pick up and convey edge and/or bleed trims generated in the production of plastic film or other thin-gauge products such as foam, paper or foil. These continuous trims are picked up by suction, conveyed into the inducer's venturi section and blown to a destination such as a Process Control film grinder or waste container.

### Standard Features

- 5-20 HP AC, TEFC motors
- Power Requirements: 480V/3PH/60Hz
- Starter electricals and controls included in ASR<sup>®</sup> System
- Silencer on the fan inlet
- Mild steel construction
- High gloss enamel paint in PCC standard color

### Options

- Interconnecting tubing and hardware
- Venturi inlet ball-mouth
- Edge and/or bleed trim pickup manifolds
- Silencers on the venturi inlet and outlet
- Special electricals
- Special paint

## GF SERIES Film Grinder



GF Series grinders are designed to provide efficient, uniform grinding of film scrap. There are four cutting chamber sizes available along with eight\* different Hp motors to accurately match the grinder to the required scrap rate. The GF Series grinders are available in configurations that accept edge and bleed trims, roll scrap, and loose scrap.

\* [PCC offers grinder motors with 5, 20, 30, 40, 50, 60, 75, 100 Hp]

Reintroduction of roll scrap is achieved with the attachment of an optional RF Series roll feeder (shown). The roll feeder has knurled rolls that provide a strong pull on the film, without wrapping. Also shown, is the AEN Air Eliminator which separates conveying air from edge trims.

### Standard Features

- ODP motor with 4-sided belt guard (TEFC motor on GFB)
- Open rotor cutting chamber with outboard bearings
- 2HP scrap conveying fan (5HP on GFD)
- Mild steel construction and Carbide-coated knives
- Remote-mount control panel
- Power Requirements: 480V/3PH/60Hz

### Options

- Hydraulic lift for opening cutting chamber
- Sound enclosure
- AEN air eliminator separates conveying air from trims
- RF Series roll feeder
- Special electricals
- Special paint

## RMX SERIES Refeed Machine

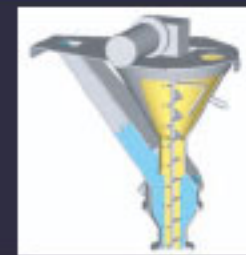

The RMX Series refeed machine is designed to meter the ground scrap with virgin pellet materials back into the production extruder at a consistent scrap-to-virgin ratio. The outer compartment contains virgin material which is gravity-fed to the throat. The virgin material completely surrounds the ground scrap as it enters the extruder. The extruder screw receives a consistent column of compacted ground scrap surrounded by virgin material, providing consistent operation without extruder surging or starvation.

### Standard Features

- Drive System: DC Motor, SCR speed control, NEMA-12 enclosure
- Power Requirements: 230V/1PH/60Hz
- Mild steel construction
- High-gloss enamel of PCC standard color

### Options

- Isolation transformer for use with non-230V, 1PH
- Additive feeders
- High efficiency cyclone and cyclone filter assembly
- AC Motor

# Comparing Gravimetric Continuous and Batch Blending

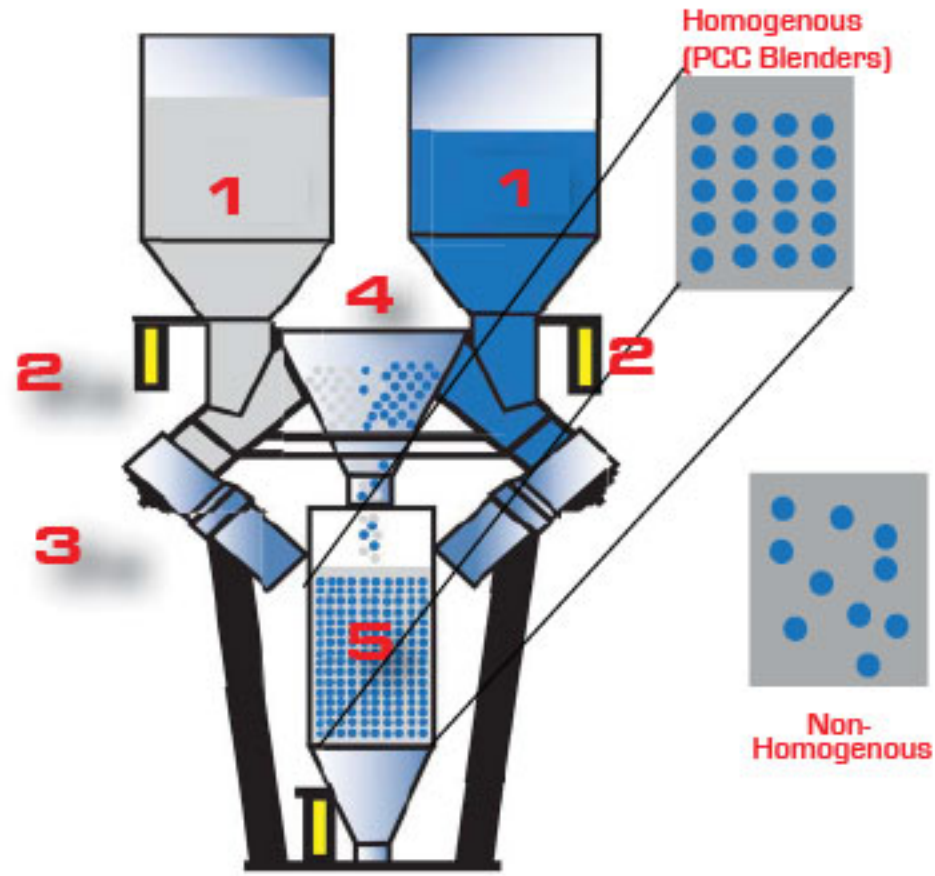
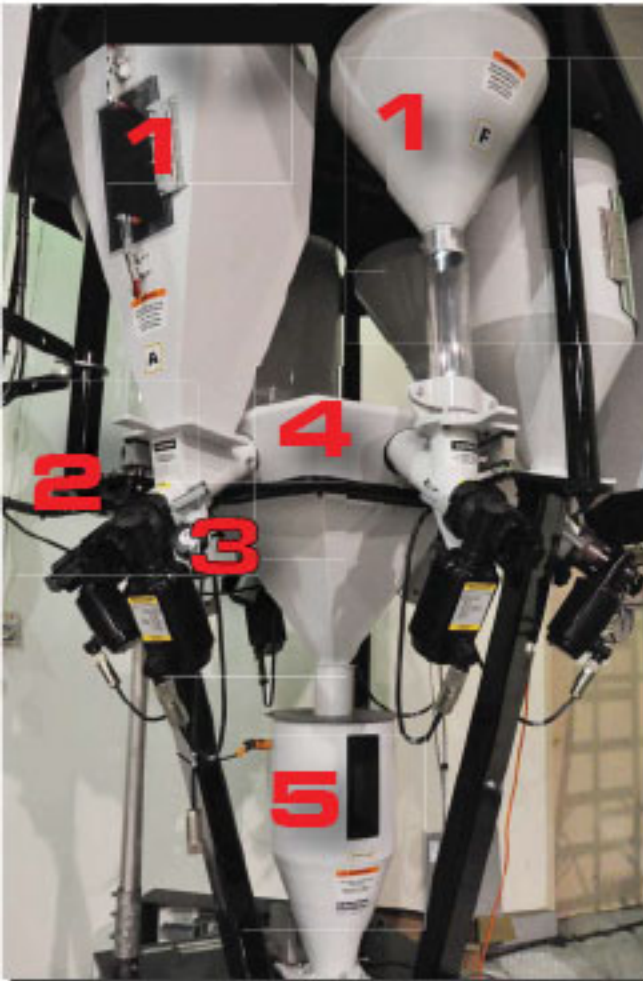

## Continuous Blender Operation

Materials are kept in separate material hoppers (1), each mounted on a load cell (2) which measures the weight of the hopper and its contents. Target metering rates are determined for each material based on the recipe and the overall total blender throughput rate. As the material is simultaneously metered by the auger (3) into the cascade mixing chamber (4), the actual metering rate of each ingredient is frequently calculated from the weight loss of the hoppers. These actual rates are compared to the target rates, and the speeds of the augers are automatically adjusted to correct for any variation, maintaining an accurate blend. The materials simultaneously flow through the cascade chamber, which thoroughly homogenizes the blend. The resultant blend is then captured in a plug-flow optimized weigh hopper (5), designed to preserve the blend homogeneity on the way to the extruder.

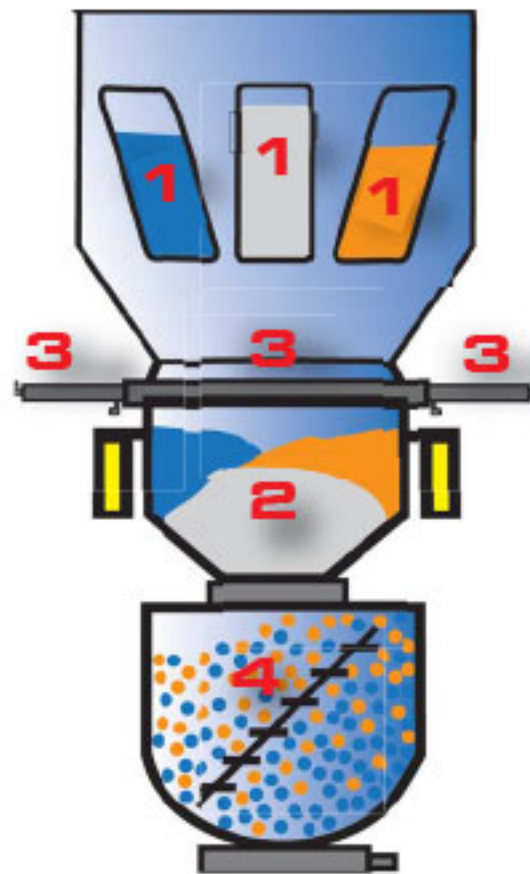
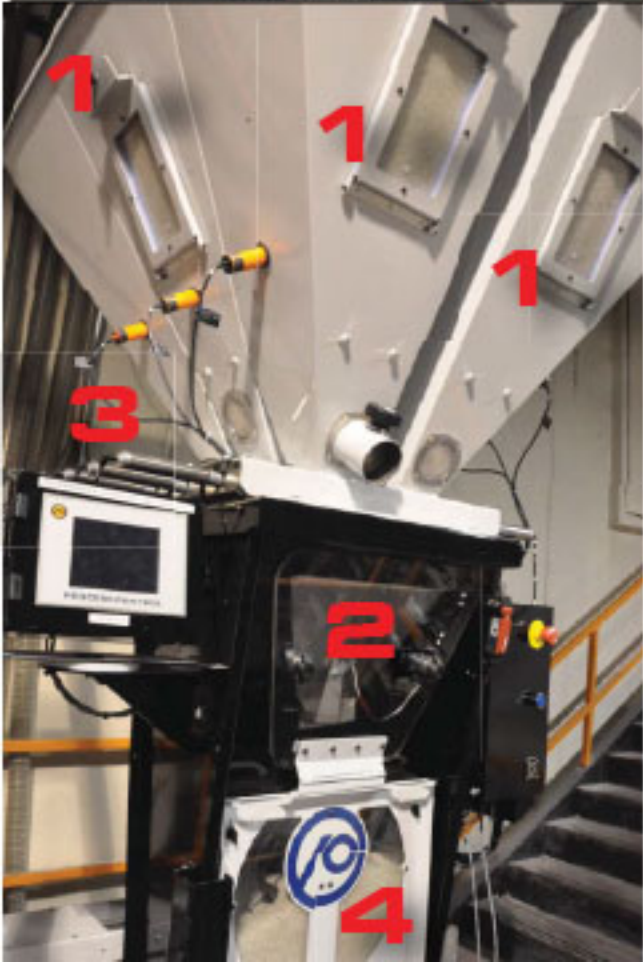

## Batch Blender Operation

Materials are kept in separate material ingredient hoppers (1) above a central batch weigh hopper (2). The metering gates (3) are controlled with one initial dispense cycle and then the balance of the requested weight amount is fine-tuned by "pulse cycling" the gate. At this point, the materials are gravity fed into a mixer (4) which agitates material for a fixed time period, homogenizing the blend. At the end of the mix cycle, the blend is then available for processing by the extruder, or for the next step in the overall process.





## Precision Blending

X Series 2 Continuous Gravimetric Blenders are designed to produce precise, homogenous blends by weight, regardless of ingredient bulk densities. In order to accomplish such precision, Process Control utilizes the latest in micro-processor technology for total automation of process functioning/monitoring, recipe entry and storage and inventory control. Functions are actuated through a 6" color touchscreen. These functions are menu-driven, and step the operator through the required sequences of actions with simple instructions.

## Benefits and Advantages

- o Improved product quality and consistency
- o Reliability, operational longevity and ease of use
- o Minimize use of expensive ingredients for overall reduced manufacturing costs
- o Reduce inventory of blended materials  
Allow faster startups and product changeovers
- o Provide inventory and production reports for management
- o Reduce labor costs through automatic operation
- o Reduce scrap of off-spec product
- o Ethernet port standard; can be networked for remote monitoring operation, and can communicate with other systems for complete plant level control

## X Series 2 Features

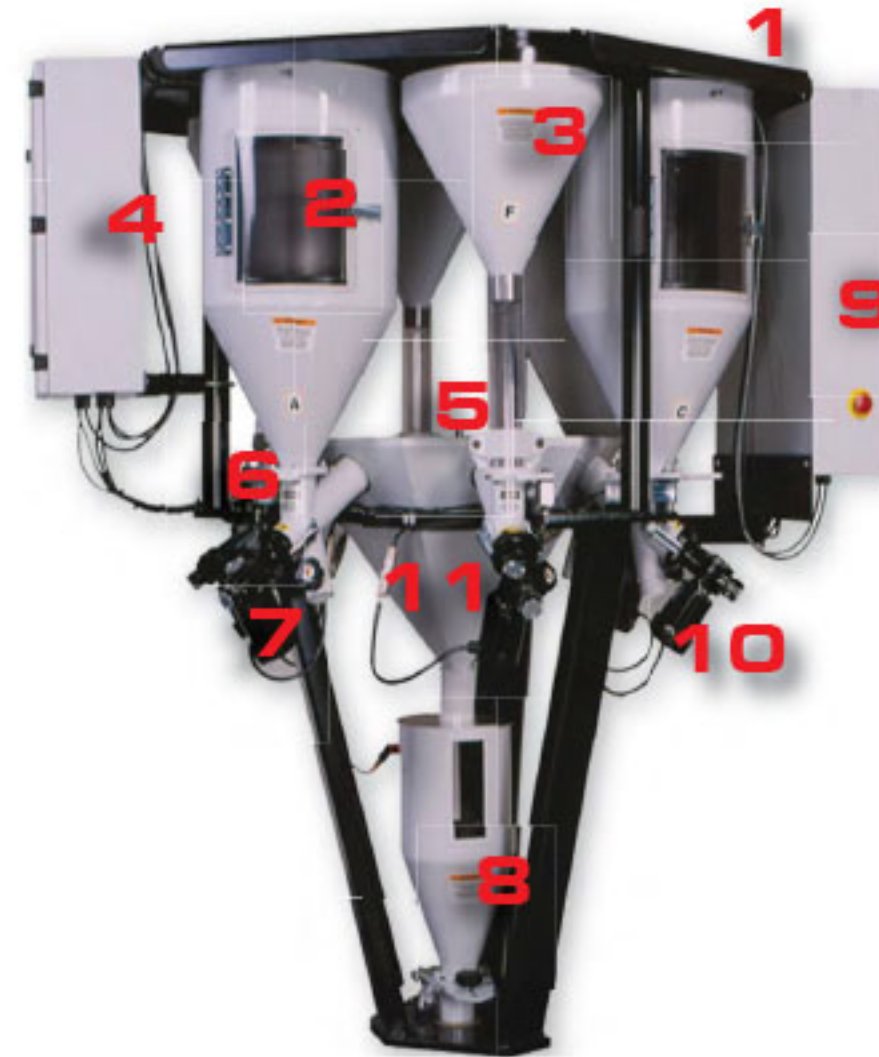

### Optional Steep Wall Regrind Hoppers Utilized to Promote Flow

Materials which do not flow well, such as regrinds and flake, can create problems. With standard feeder designs, these materials can feed inconsistently and can even "bridge", causing all feeding to stop.

To solve these problems, Process Control employs optional steep wall regrind hoppers with enlarged feed openings when necessary to promote consistent material flow.



- 1 Integral Loader Support Platform supports typical loading equipment without external support
- 2 Clear Polycarbonate Access Doors allows visual inspection and cleanout of hopper contents
- 3 Low-Rate Tube Hopper precisely meters critical additives at low rates
- 4 Onboard Drive Electronics uses a brushless drive control system to precisely control feeder speeds
- 5 Large Cascade Chamber Cover for easy cleanout
- 6 Ingredient Hopper Load Cells accurately measures material metering/weight loss in real time
- 7 Quick-Change Auger/Metering Units uses variable speed brushless DC gear motors with closed-loop control for precise ingredient measuring
- 8 Integral Downcomer maintains supply of blended material for use by your processes. Plug-flow design avoids de-mixing of blended ingredients.
- 9 Onboard Weighing System digitizes load cell signals for error free transmission to central PLC controller
- 10 Material Cleanout Drains with manual valves enables quick material cleanout and changeovers
- 11 Cascade Mixing Chamber thoroughly homogenizes blend with no moving parts



## XU SERIES BLENDER



- 1** Universal Frame  
available in both 4 and 6 element configurations
- 2** Stainless Steel Weigh Hoppers  
electro-polished; also available in food grade stainless steel
- 3** Gear Motors  
variable speed brushless DC gear motors with closed-loop control for precise ingredient measuring
- 4** Feeding Area  
round-to-trough and agitated design, for more consistent mass flows
- 5** Material Supply Hoppers  
with flapper valves; optional knife gate valves for improved performance are available
- 6** Cascade Chamber  
for mixing all of the ingredients
- 7** Metering Augers  
available in a full pitch or 1/2 pitch configurations, and in up to 2-1/4 inch diameter feed tube sizes
- 8** Weighing Platform  
with incorporated dual load cells, anchored with quick clamps for easy removal and cleanout

### Blender Mounting Options

Extruder Throat Mounting



#### Extruder Throat Mounting

When space is available, the blender with integral downcomer may be bolted directly to the throat. This is the simplest installation and provides excellent blend homogeneity and cleanout.

Mezzanine Mounting



#### Mezzanine Mounting

For applications with an existing mezzanine structure above, this arrangement offers the benefits of throat mounting. This blender configuration uses a remote downcomer mounted on the extruder throat to capture the gravity-fed blend of materials from the mezzanine mounted blender.

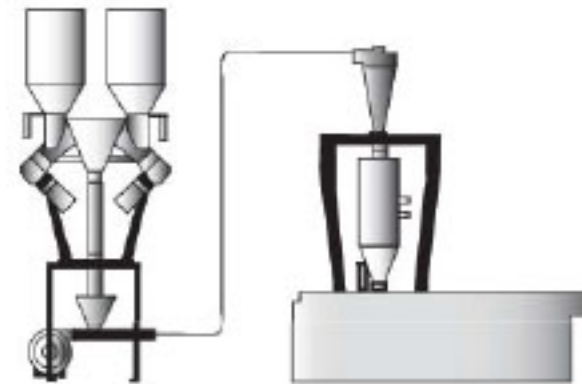

Off-Line Mounting with Pressure Conveying

#### Off-Line Mounting with Pressure Conveying

For applications where the blender must be mounted off-line, the pressure conveying system offers the benefits of extruder throat mounting. As the blend is produced, it is conveyed via pressure continuously to the extruder throat mounted remote downcomer. This prevents demixing and allows accurate calculation of extruder rate for gravimetric extrusion control applications.

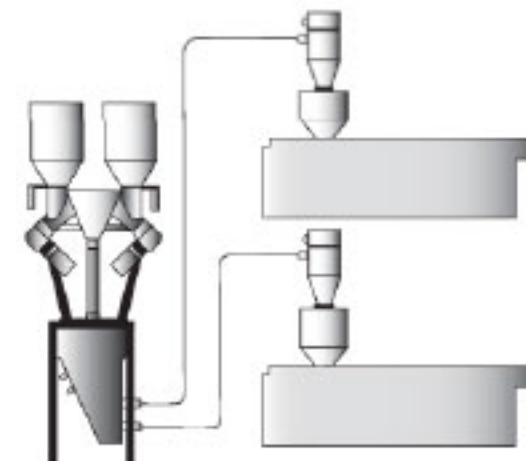

Off-Line Mounting with Vacuum Conveying

#### Off-Line Mounting with Vacuum Conveying

For applications where there is not enough headroom for either throat or mezzanine mounting, or where more than one extruder is to be served by the same blender, off-line mounting is to be used. The blender is mounted on a stand with a vacuum pickup box below it to capture the material blend. On demand, the blend will be vacuum-conveyed to the machine[s] being served. Care must be taken to minimize the chances for blend separation during this conveying.

GUARDIAN® SERIES 2



See-Through Front Access Mixing Chamber Door



Easy Open Hopper Doors



No Dead Space Mixing Chamber With Welded Single Piece Scroll

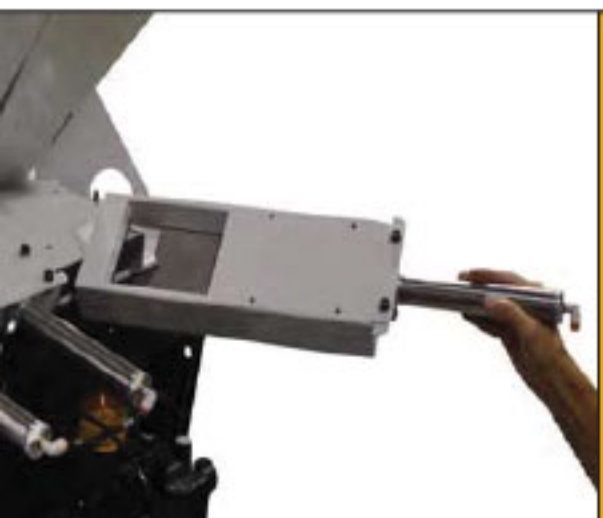

Cartridge-Style Metering Gate



Removable Weigh Hopper

Simplicity of Operation

Accurate Dispensing

Superior Blend Homogeneity

**SIZES:**

- 2.2lbs (1Kg).
  - 5.5lbs (2.5Kg).
  - 11lbs (5Kg).
  - 26.5lbs (12Kg).
  - 40lbs (18Kg).
  - 55lbs (25Kg)
- With 2-12 Elements



Standard Sightglass, Optional Drain Chute

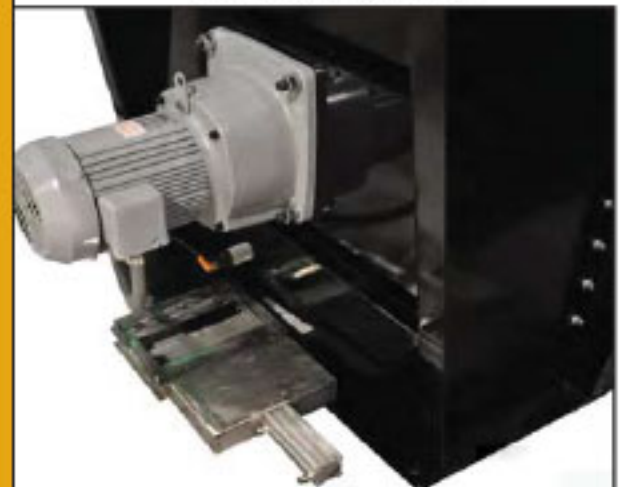

Mixer Unload Cartridge Gate

## Guardian® 2 Features

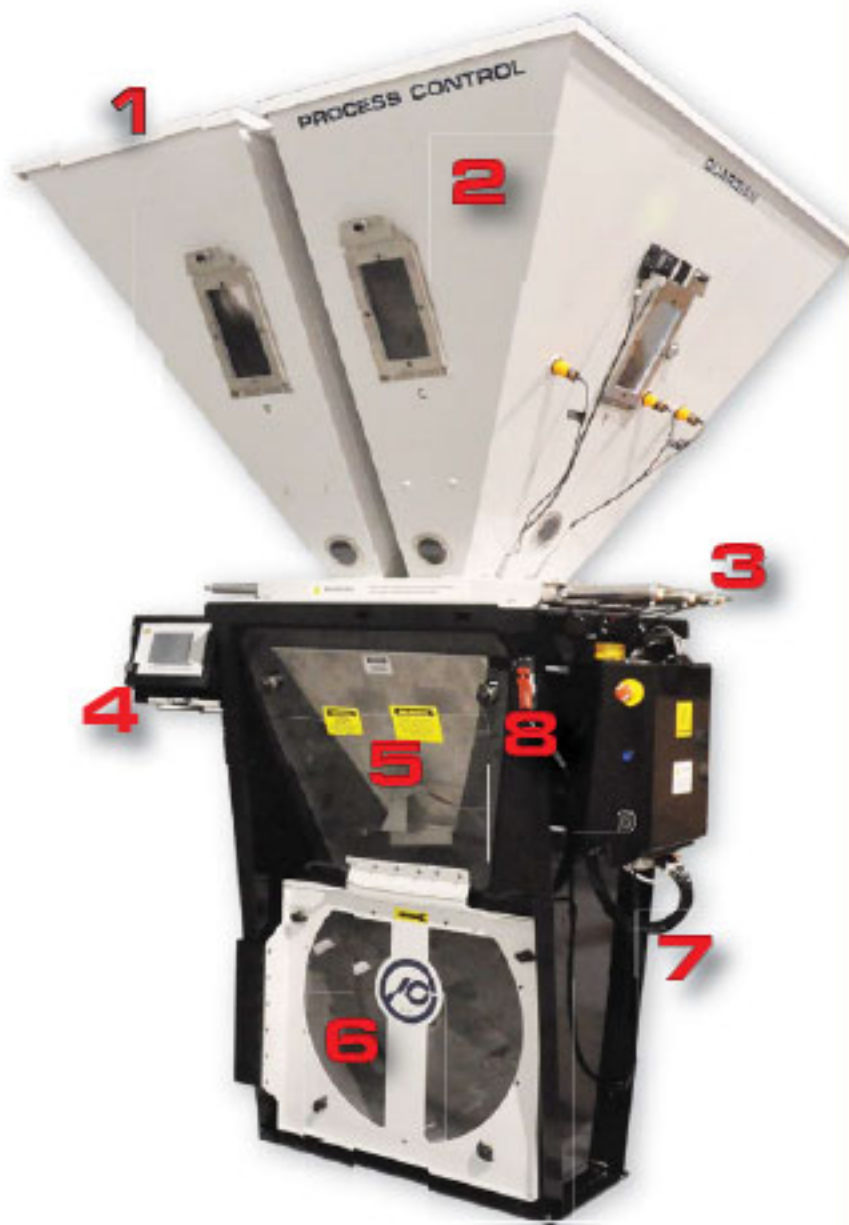

- 1** Integral Loader Support Platform supports typical loading equipment without external support
- 2** Segmented Material Hoppers
  - Blenders have 4-to-8 elements in individual fixed hoppers that are rigidly welded together.
  - Special configurations are available for up to 12 ingredients.
- 3** Pneumatic Metering Gates
  - Pulsing V-gates achieve dosing accuracy of every ingredient in each and every batch.
  - Restricted metering gates optionally available for ultra-high accuracy at very low ingredient percentages.
- 4** Touchscreen PLC Microprocessor with Built-in Ethernet Port
  - Color touchscreen operator interface insures ease of setup/use, and startups.
  - Remote Communications Capabilities standard; various protocols supported
- 5** Weigh Hopper
  - Rests on dual load cell platform
  - Easily removable with no tools for cleaning.
- 6** Mixing Chamber
  - Agitator designed for waterfall mixing to ensure every batch is thoroughly mixed.
  - Engineered for NO DEAD SPOTS and achieves a consistent homogeneous blend.
  - See-through mixing chamber door allows for visual monitoring of blend quality.
- 7** Air Hose
  - The attached air hose and blow nozzle ease the cleaning process
- 8** Clean-Out Dump Chute
  - Fixed inside the blender behind the weigh pan for ease of material change-over.



## Integrated Controls at Your Fingertips

The 6" color touchscreen microprocessor controller comes standard on all batch and continuous blenders, and is available in an upgrade package for all existing PCC models.

In order to produce a desired blend of materials, the operator presses **RECIPE** and enters the recipe, which consists of the percentage by weight for each ingredient. The recipe may be keyed in directly or recalled from up to 400 stored recipes. The operator then presses the **AUTO** button to start blending. Once the blending has started, the computer continuously monitors the blend operation and corrects the individual feeder speeds to maintain the desired blend ratios.

- o PLC touchscreen operator interface that insures ease of use and quick startups
- o Standard Ethernet port for communication ability and integration with remote systems
- o Performs a test dispense for metering
- o Supports 6 different foreign languages
- o Performs automatic calibration when a new recipe is entered
- o Can be remote mounted up to 1000 ft away
- o Shows in real time the actual throughput and the maximum throughput based on the current recipe running
- o SCADA capable for plant wide integrations

## Control Extruder Output by Weight

Line speed control for complete control of product weight per length

Can be retrofitted for both mono- and coextrusion applications.

Exacts complete control of layer ratios and total line throughput

Gravimetric blending control of extruder output by weight

## Coextrusion System

Both the blender and weigh hopper report actual extruder usage back to the central Gravitrol computer

Line speed can be adjusted automatically for complete control over product weight per length

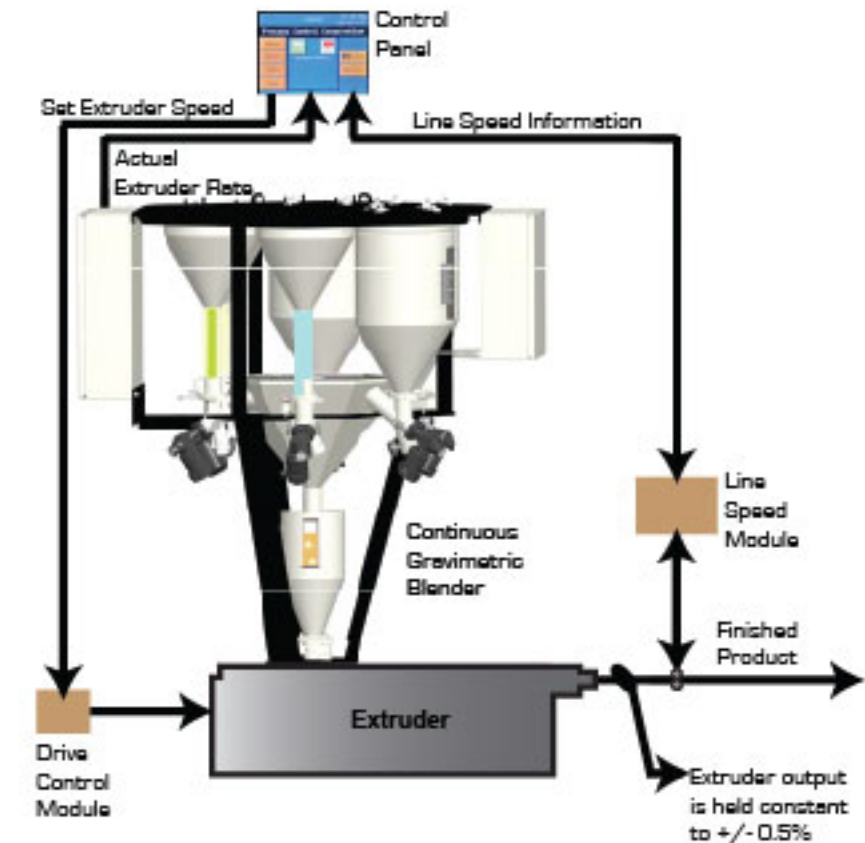

## Blender Operation with Extrusion Control

The operator presses **RECIPE** and enters the desired blend percentages by weight and the desired extruder rate into the operator station. When **RUN** is pressed the blender automatically maintains the desired blend percentages by weight. Simultaneously, the blender computer calculates the actual extruder usage rate and periodically adjusts the extruder screw speed to maintain extruder output to +/- 0.5% by weight.

In applications which incorporate line speed control, the operator also enters desired weight per length as part of the recipe. The computer then automatically controls line speed in addition to extruder speed, to maintain the desired product weight per length.

## Benefits

- o Improved product quality
- o Reduced material usage
- o Quicker startups & product changeovers
- o Reduced scrap
- o Improved product repeatability
- o Accurate inventory reporting
- o Improved identification of off-spec product



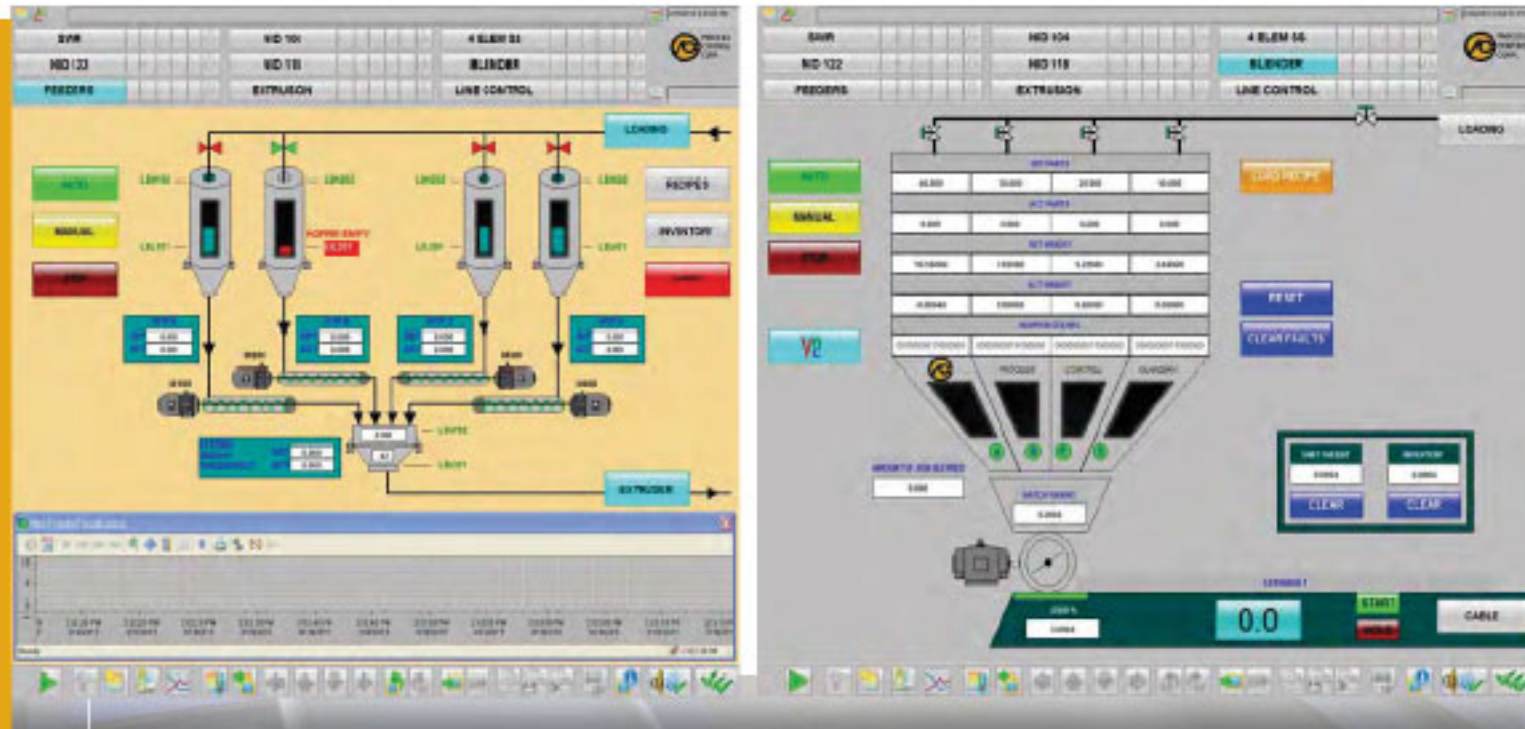

## Complete System Integration Services With Siemens WinCC, Wonderware, and GE Cimplicity

PCC integration services utilize SCADA process visualization software. The standard package includes: Monitoring and controlling PCC Continuous Blender, PCC Batch Blender or PCC Gravitrol weigh hopper [with B&R touchscreen, or Mini-Op equipped with ethernet capability]. One license will be provided for one computer only.

### Features

- o Monitor fully integrated systems from a centralized location  
Real time blender operations
- o Historical trending
- o Material Usage & Alarm Log
- o Exports to any spreadsheet program
- o Connectivity with Modbus RTU & IP, Allen-Bradley E/IP & CIP  
Profibus DP, Profinet

## PROPER MATERIAL LOADING IS CRITICAL

### Continuous Gravimetric Blenders Require Proper Sizing of the Loading System

With all blenders, and especially with continuous blenders, it is very important that material be delivered in a timely manner to the ingredient hoppers. Process Control takes the guesswork out of this selection by providing a complete guaranteed system based on your material usages and conveying distances. Our experienced industry and engineering staff, computer simulation modeling, and practical experience with a wide array of real world applications assures you of a vacuum conveying system that meets your requirements.

### Blender Ingredient Loading is Fully Automated

The blender ingredient hoppers call for materials as required, while the system directs the operation of the pump and vacuum receivers to ensure that materials are loaded to the proper stations at the proper times. Standard PCC material receivers utilize proximity switches mounted in a location that will deliver the optimum refill size. The receivers fill until the specified volume is reached, eliminating the need for setting fill times. Loading by volume is more precise than loading by time and maximizes the output of the loading system.



### Vacuum Power Units

Our Vacuum Power Units offer dependable and economical performance for a wide variety of conveying rates, distances and materials. Typical applications include in-plant distribution systems and blender/machine loading.



Easily removable pellets screens are standard on all pellet receivers



### Vacuum Receivers

Our Vacuum Receivers come in a range of sizes and designs for handling pellets, regrinds or granular/dusty materials. Our vacuum receivers are designed to be mounted at any point where resin delivery is needed.



## COMPLETE TURN KEY SYSTEMS

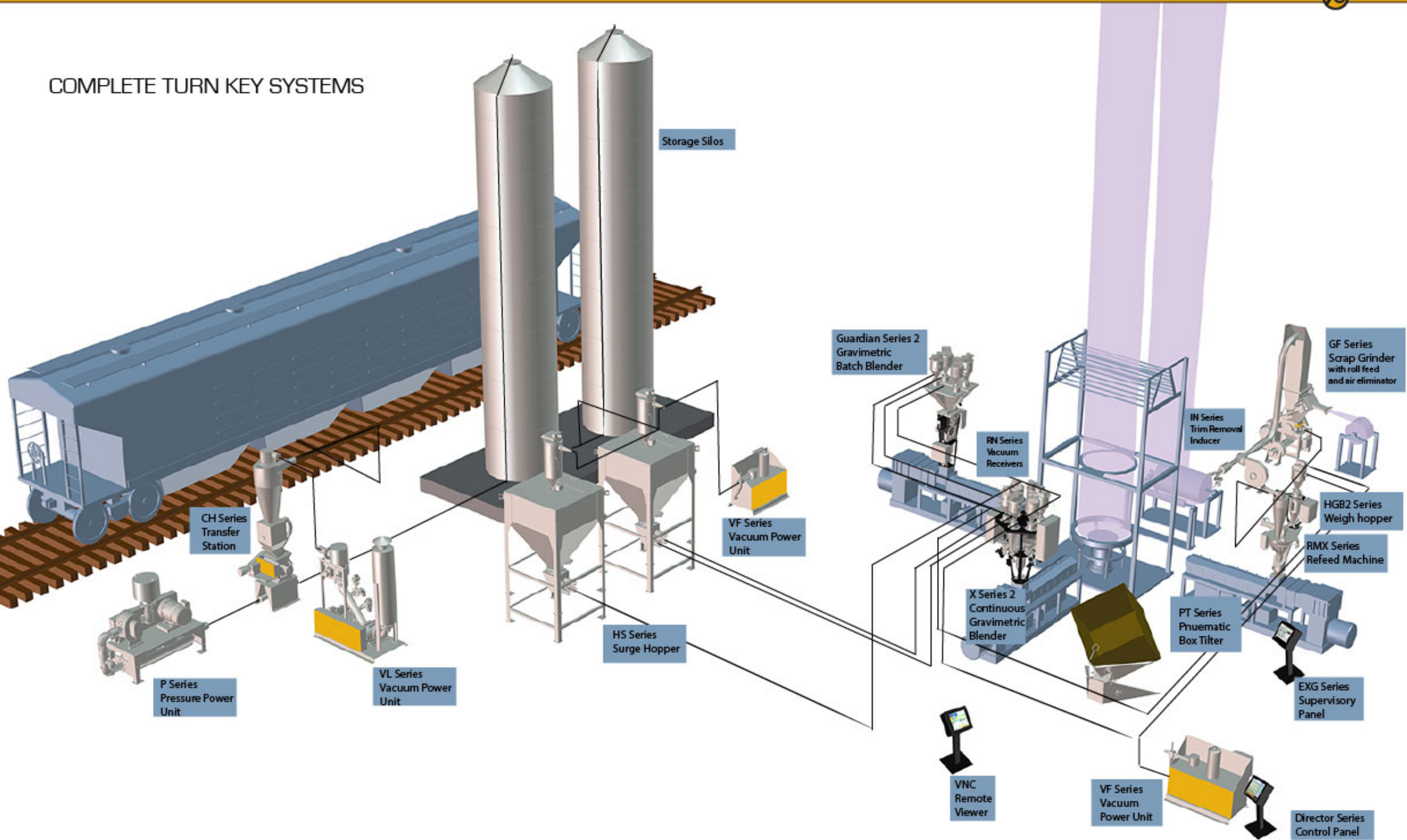



## Director™ Conveying System Sequencing Panel

The Director™ sequencing panel provides automatic control for your complete vacuum conveying system. The sequencing panel controls the vacuum pump and vacuum receivers to select which receiver is being loaded and the duration of the load.



## Desiccant and Hopper Dryers

PCC Desiccant Wheel and Hopper/Hot Air dryers provide manufacturers and businesses with a wide variety of solutions for their particular plastics drying and/or dehumidification needs. Typical features across various models include process stability, comparative energy efficiency, and uniform process and regeneration heating operations.



## Railcar Unloading System



### VP Series Vacuum/Pressure Unit

The VP Series Vacuum/Pressure Power Unit is typically used as part of a truck or railcar unloading system. It is designed to pull material to its transfer station, where it passes through a rotary feeder to the pressure side of the system. The material is then blown to a storage container, such as a silo or daybin. The VP Series can be part of an integrated plant distribution system designed by Process Control to meet your specific needs.

- 10 to 50 horsepower available
- Positive displacement blower
- T-frame TEFC motor
- Enclosed V-belt drive
- Discharge silencer
- Vacuum relief valve and gauge
- Level control
- Dual-stage intake filter



### VL Series Vacuum Power Unit

The VL Series vacuum power unit is designed for use as part of a complete dual-blower railcar or truck unloading system. The power unit pulls material (using vacuum) from a source to a CH Series transfer station. Then, the material drops through a rotary feeder, to a blow through by a P Series pressure unit.

- 10 to 60 horsepower available
- Positive displacement blower
- T-frame TEFC motor
- Dual-stage intake filter
- Discharge silencer designed for effective sound reduction
- Vacuum relief valve and gauge
- Reinforced, heavy steel plate
- Four-sided belt guard with removable access cover
- Electricals and controls in a NEMA-12 enclosure
- Power: 460V/3Ph/60Hz



### CH Series Transfer Station

The CH Series transfer station, with cyclone, is designed for use in dual blower conveying systems. Used in conjunction with the VL Series vacuum pump and P Series pressure pump, the CH Series is used to transfer the material from the vacuum part of the system to the pressure part of the system.

- Rotary feeder with shear eliminator and vent
- Polyphase gearmotor Power: 460V/3Ph/60Hz
- High efficiency cyclone designed for air flow as required
- Level control rotary vane, electro-mechanical type
- Four-sided chain guard with removable access cover
- Reinforced heavy steel base plate
- Mild steel construction



### P Series Power Unit

The P Series Power Unit is designed for quiet, reliable performance in a pressure conveying system or as part of a dual-blower vacuum/pressure system. Typical applications include railcar/truck unloading and in-plant distribution systems. Eleven standard P Series units are available, with horsepower ratings from two to sixty.

- Positive displacement blower
- T-frame motor
- Cartridge intake-side air filter
- Intake- and pressure-side silencer
- Four-sided belt guard with removable access cover
- 2 to 60 horsepower available
- Reinforced, heavy steel plate
- NEMA-12 electrical/control enclosure
- Adjustable pressure switch with diaphragm-piston transducer





**X Series Continuous Gravimetric Blender**



**XU Series Continuous Gravimetric Powder Blender**

Process Control offers a new selection of upgrades for Continuous Gravimetric blenders, including a color touch screen controller, brushless motors and drives, and a DSP weigh module upgrade kit, that will improve your blender's performance and longevity. These upgrades not only add years to your blender's life, but can actually improve your blender's accuracy as well. These upgrades offer a way to simplify the blending process and postpone future blender replacement, making operation easier and saving you money all at once. Your older Continuous Gravimetric blender controls, drives, and weigh module chips are facing the threat of becoming obsolete; ensure that will not happen by upgrading today.



**New Motor Drives can operate with either new brushless or older permanent magnet**



**Brushless Gearmotor installed on an X Series Continuous**



**The new touch screen controller for Continuous Blenders**



**Autobatch Blender**



**Guardian® Blender**

Process Control offers a new touch screen controller for Autobatch and Guardian® blenders that is an off-the-shelf solution to improve your blender's performance and longevity. This non-proprietary upgrade will not only add years to your blender's life, but it will actually improve your blender's accuracy and output as well. The upgrade is also a way to simplify the blending process and postpone future blender replacement, which makes things easier and saves you money all at once. Your older Autobatch or Guardian® controls are facing the threat of becoming obsolete; ensure that will not happen by upgrading to our new touch screen control system today.





## PROCESS CONTROL CORPORATION

*Do It Right The First Time, Every Time!*

### WORLD HEADQUARTERS

6875 Mimms Drive  
Atlanta, GA 30340, USA  
P: 770.449.8810  
F: 770.449.5445  
sales@process-control.com  
www.process-control.com

### PROCESS CONTROL GmbH

Industrie Strasse 15  
63633 Birstein, Deutschland  
P: (+49) 6054.91290  
F: (+49) 6054.9129.99  
info@processcontrol-gmbh.de  
www.processcontrol-gmbh.de

For detailed product information, including specs and dimensions, please request a PCC data sheet or download one from our website



For more information about the company and other PCC products, please visit our website at:  
[www.process-control.com](http://www.process-control.com)

The screenshot shows the Process Control Corporation website. At the top, there is a navigation menu with links for Home, About Us, Products, Services, and Contact Us. The main content area features a large banner with the text "Process Control Corp. is a global leader in solution driven process control technology" and "QUALITY DESIGN RELIABILITY AND INTELLECTUAL PROPERTY PROCESSING TECHNOLOGY". Below the banner, there are several product images and a large image of a Guardian Series 2 machine. The website also includes a footer with the company name, address, and contact information.



American Made Quality - Since 1967