

XU Series 2 Continuous Gravimetric Powder Blender



Mechanical Features

- ◆ Individual weighed ingredient hoppers with easy-to-use drains.
- ◆ Interchangeable metering units with quick disconnect.
- ◆ Brushless DC gearmotors with drive control and closed-loop speed regulation.
- ◆ Integral loading platform for mounting surge bins/vacuum receivers.
- ◆ Designed for easy cleanout and quick changeover, no tools required.
- ◆ Stainless steel construction, food grade optional.
- ◆ Standard 4 and 6 element universal frames.

Control Features

- ◆ Blender monitors weight loss of each ingredient hopper for precise control of blend ratios.
- ◆ Weighing system resolution is 1:1,000,000 for maximum accuracy.
- ◆ Color touch screen display for easy viewing of inventory and performance data.
- ◆ Storage for 400 blend recipes in battery-backed memory.
- ◆ Multiple alarm levels with visual display and contact closures.

The XU Series 2 Continuous Gravimetric Powder Blender offers unsurpassed blend accuracy and blend homogeneity in a wide range of configurations to meet the needs of any application by incorporating the PF Series powder feeders. It allows gravimetric blending of non-free-flowing powder materials with free-flowing powder and pellet materials at unprecedented metering and mixing accuracy.

The powder feeders allow rates as low as 0.2PPH and as high as 6,000PPH. Metering augers are available in full pitch or 1/2 pitch configurations with helix diameters from 1/4 inch to 2-1/4 inches.

The drive system of all blender components utilizes a motor drive with a brushless DC gearmotor and encoder for accurate motor speed feedback. This allows each of the individual feeders to maintain a constant RPM and weight throughput.

The weighing system is designed with DSP (digital signal processing) technology to filter out unwanted

noise and vibration which can cause inaccurate feeding rates, especially at very low rates.

Incorporated into the electro-polished stainless steel design is a patented round-to-trough feeding area which provides more consistent mass flow for better metering accuracy. The feeder is designed with a steep wall, removable hopper which features a dust-tight band clamp for easy mounting of hopper extensions and quick disassembly for clean out. The bottom trough design is optimized to provide maximum material exposure to the auger.

The XU Series 2 Continuous Powder Blender is also available in food grade stainless steel.

The operator enters the desired blend recipe at the operator station. All ingredients are simultaneously metered in the correct blend ratios by augers from individual weighed PF Series powder feeders. The ingredients then flow through a cascade chamber which produces the best blend homogeneity.



PROCESS CONTROL CORPORATION

World Headquarters
6875 Mimms Drive, Atlanta, GA 30340 USA
Ph 770.449.8810 Fax 770.449.5445

Process Control GmbH
Birstein, Germany
Ph +19-6051-91 29-0 Fax +19-6051-91 29-99

Features of XU Series 2 Continuous Powder Blender

1 Universal Frame

The universal frame is available in 4 and 6 element configurations.

2 Stainless Steel Weigh Hopper

The stainless steel weigh hoppers are electro-polished and available in food grade.

3 Gear Motor

Brushless drive and gearmotor with encoder.

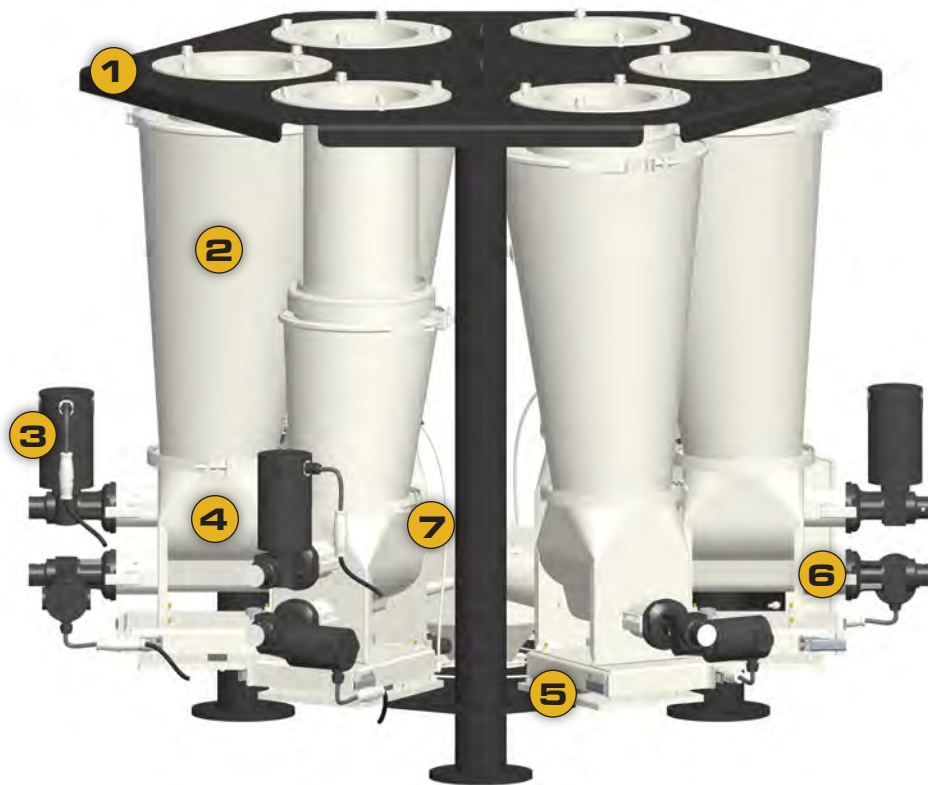

4 Feeding Area

The feeding area is round-to-trough and agitated.

5 Dual Load Cell

The dual load cells are weighing platforms with quick clamps.

6 Auger

The auger has a 1/2-1" pitch and up to 2-1/4" diameter.

7 Cascade Chamber

The cascade chamber is for mixing all of the ingredients.

Standard Features

- All mechanical components are disassembled from the drive end, without the use of tools.
- Communication protocols supported include EtherNet/IP, Allen Bradley (dh+), CCM, Siemens, Modbus TCP and Modbus/Extended, as well as proprietary EPC and ASCII
- 4 or 6 element frames for mounting a variety of feeder options.

Optional Features

- Pellet/Regrind Element
- Gravimetric Extrusion Control
- Steep-wall surge bins with knife gates for feeder loading
- High temperature design
- FDA Stainless Steel
- Power:
115V/1Ph/60Hz or 230V/1Ph/50Hz